

BOLT ON BALCONY

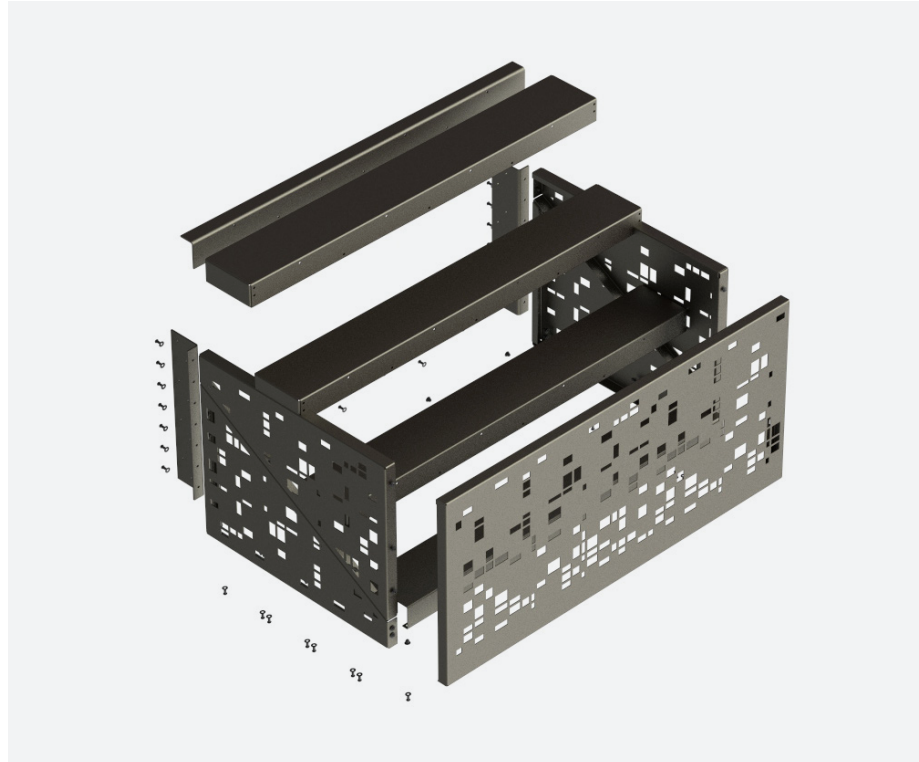

IT IS A COMPLETELY DIFFERENT INSTALLATION SEQUENCE.

- Fewer trades involved means lower install costs. Traditionally, one trade builds the framing, another trade installs brackets, and another trade waterproofs, then another trade installs a finished floor. The brackets are then field measured so the panels can be released.
- The Bolt-on Balcony allows one trade to install our brackets to the wall framing. The exterior wall is waterproofed and finished and the entire balcony assembly is installed.
- Unlike competitors, our system does not require unsightly hangers. The final install is visually simpler and works more cohesively with the architects intent.
- All the balconies can be built on the ground or on the building. Our built in tolerancing of +/- 1" keeps balconies more typical and ensures an easier install.

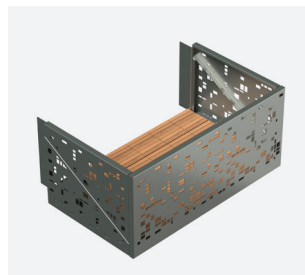

TEAK 85



TEAK 86



WALNUT

BOKMODERN.COM

For any questions please call
415.749.6500 X 295

BOLT ON BALCONY

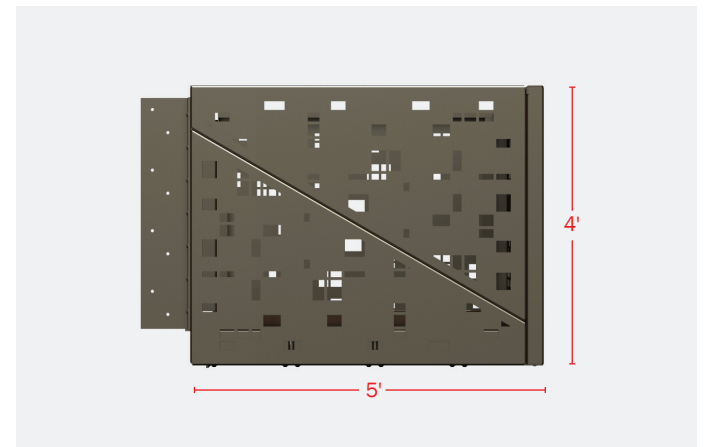
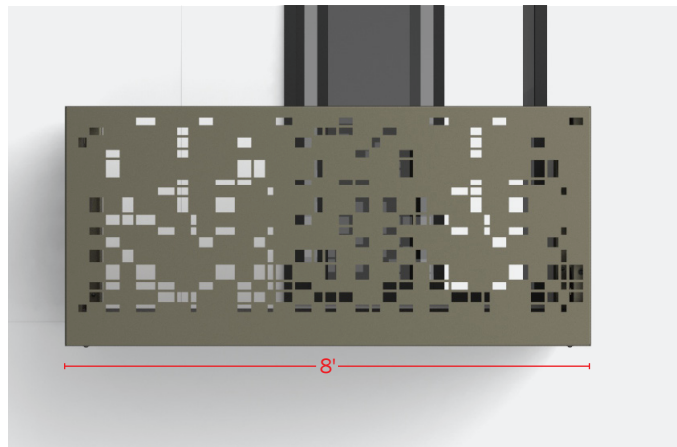

- Engineered for 5'x8' footprint on buildings up to 60' tall in both Aluminum and Corten.
- For larger sizes or higher elevations, please reach out to info@bokmodern.com to inquire about a custom Design Contract.
- The Bolt-on Balcony has a unique water management system built into the floor boards that redirects water away from the building and off of lower level balconies.
- Wood tile flooring option.

BOKMODERN.COM

For any questions please call
415.749.6500 X 295