



**TAB & SLOT
RAINSCREEN**



—
SFO
GRAND HYATT
SAN FRANCISCO

BOKMODERN.COM

PATENT# 9,903,122, 10,190,320 - 2018

**TAB & SLOT
RAINSCREEN**

- Introduction
- Thermal Expansion and Critical Lighting
- 2D Patterns
- 3D Patterns
- Pre Engineered Sizing
- Optimized Sizing For Cost Efficiency
- Installation Examples
- Installation Methods
- Typical Details



ABOUT BOK MODERN

We are a team of architects, industrial designers, engineers and contractors. We understand your vision and facilitate your project from concept to delivery.

We provide elegant, structurally integrated panel solutions for balcony guardrails, fences, rain screens, canopies, parking garage screens, green screens and much more.

WHY BOK MODERN RAINSCREENS?

BOK Modern's patented Rainscreen system is like no other on the market. Our Rainscreen is a non-flammable, solid aluminum, single skin panel; not a composite. The folded crisp edge result in a super flat face. It can be solid, bas-relief, or custom laser cut to your specifications in aluminum or weathering steel. We can also custom form to a large variety of 3-dimensional shapes. We also offer a 12 and 14 gauge weathering steel option as well as stainless steel in a variety of surface treatments.

Standard finishes on aluminum include Kynar, in unlimited colors, powder coating and anodizing. We offer specialty coatings as well.

Our patented tab and slot system has an integrated spacing feature to space the panels without using shims to ensure a quick and easy install. When installed directly over a suitable substrate (i.e. plywood), our unitized panel system generally requires no additional furring or other secondary support members. Reducing labor costs in the field means a higher quality of panel for your project budget. When installed over insulation or other such substrate, our panels are attached directly to standard 'z's' or hat channels.

All of our panels are precision manufactured to your specifications for your specific job. All of your panels are modeled 3-dimensionally in Solidworks and fitted before fabrication. All panels are crated in solid wood crates and each panel has laser cut part numbers to insure quick identification during install.

BOK provides in-house engineering for our panels with loads for your Engineer of Record to provide the appropriate backing structure.

PATENT# 9.903.122 -2018

**TAB & SLOT
RAINSCREEN**

- Introduction
- Thermal Expansion and Critical Lighting
- 2D Patterns
- 3D Patterns
- Pre Engineered Sizing
- Optimized Sizing For Cost Efficiency
- Installation Examples
- Installation Methods
- Typical Details

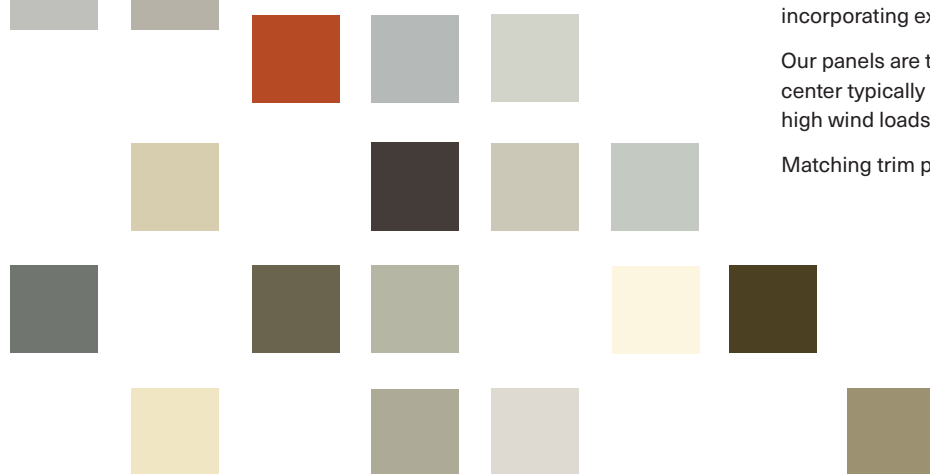

TECHNICAL INFORMATION

Our panels are a closed joint rain screening system with dry (non-sealed) joints. The panels and attaching hardware are provided by BOK Modern. Appropriate air & water barriers to be provided by others. Recommendations include:

Liquid applied:

- GE Elemax 2600 (in service temperature up to 300° F)
- Cat5 (in service temperature up to 300° F)
- Dow Defendair 200 (in service temperature up to 300° F)
- GCP (Perm-A-Barrier VPL max in service temp of 160° F)
- Soprema (Sopraseal LM)

Sheet applied options:

- GCP (Perm-A-Barrier High Temperature in-service temperature up to 180° F)
- Soprema (Sopraseal Stick VP in-service temperature up to 185° F)
- Vaproshield Revealshield SA is a black UV stable self-adhered membrane that can be used in open jointed rainscreen applications. In service temperature up to 225° F.

Aluminum panel gauges include .060, .080 and .125. See the following tables for pre-engineered panels sizing

Our system minimizes thermally broken z-girts (if required). Ask us about our soon to be released integrated furring system for assemblies incorporating exterior insulation.

Our panels are typically attached with #12 sheet metal screws 16" on center typically on the long sides. Additional screws may be required in high wind loads and/or large panels.

Matching trim pieces available upon request.

**TAB & SLOT
RAINSCREEN**

- Introduction
- Thermal Expansion and Critical Lighting
- 2D Patterns
- 3D Patterns
- Pre Engineered Sizing
- Optimized Sizing For Cost Efficiency
- Installation Examples
- Installation Methods
- Typical Details

THERMAL EXPANSION

BOK Modern offers a premium product that architect's love. We pride ourselves on our flat panels. How we can achieve this is by accommodating for thermal expansion in the panels themselves and having a complete understanding of where the expansion is going to take place. Aluminum and steel expand at a consistent rate relative to the material. The finish color also influences the expansion. Darker colors absorb more heat and expand at a faster rate. Some expansion is inevitable when the sun is at certain angles. Occasionally this minimal expansion is made more dramatic by critical light. In most cases 1/4" typical gap is sufficient.

Thermal Expansion Equations

Aluminum: $13 * F * 10^{-6}$
Corten: $8.3 * F * 10^{-6}$

CRITICAL LIGHT

Critical light is a phenomenon where flat surfaces that are very close to perfectly flat appear to have large distortions due to the angle at which light hits the surface. Typically, dramatic lighting of 15 degrees or less will create exaggerated visual distortion. This effect is magnified in photograph.

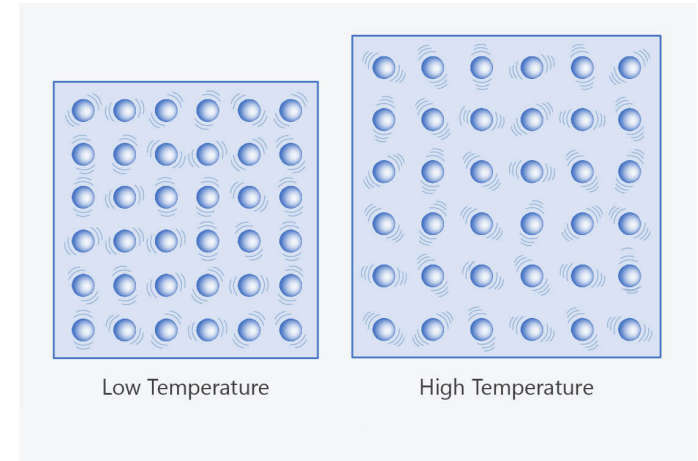

THERMAL EXPANSION OF MATTER

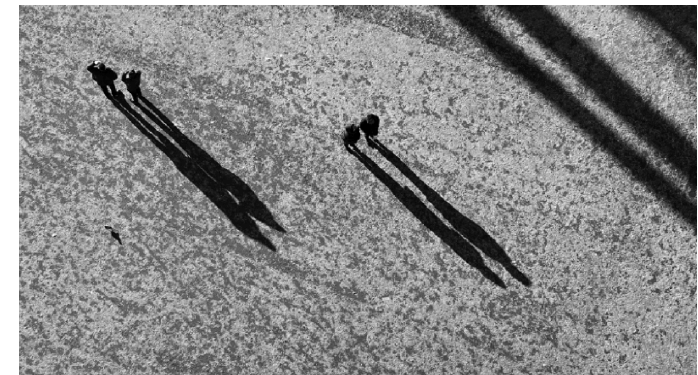

CRITICAL LIGHT

TAB & SLOT RAINSCREEN

- Introduction
- Thermal Expansion and Critical Lighting
- 2D Patterns
- **3D Patterns**
- Pre Engineered Sizing
- Optimized Sizing For Cost Efficiency
- Installation Examples
- Installation Methods
- Typical Details

3D PATTERNS

Our panels can also be custom formed for 3-dimensional applications.

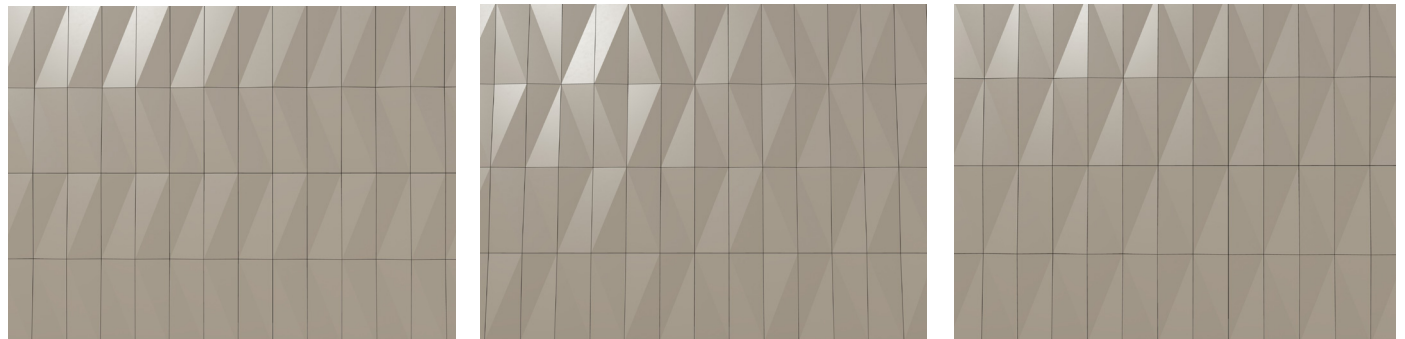

Examples of 3D pattern options

TAB & SLOT RAINSCREEN

- Introduction
- Thermal Expansion and Critical Lighting
- 2D Patterns
- 3D Patterns
- Pre Engineered Sizing
- Optimized Sizing For Cost Efficiency
- Installation Examples
- Installation Methods
- Typical Details

BÖK MODERN ALUMINUM PRE-ENGINEERED RAINSCREEN PANEL DESIGN TABLES *Based on maximum wind loading (psf)*
DEFLECTION CRITERIA *All loading based on L/60*

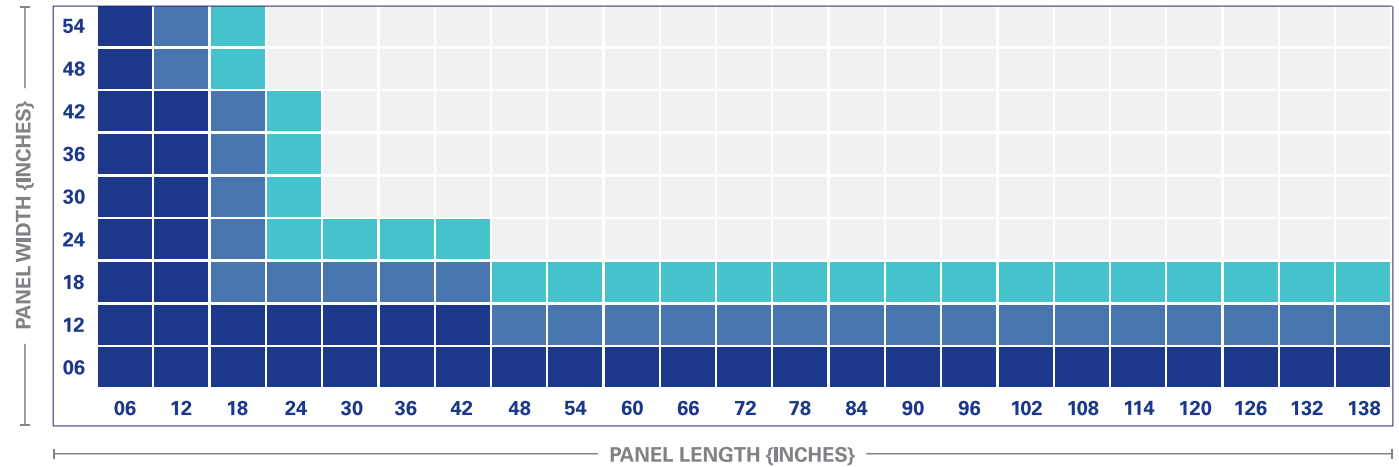

HIGH RISE BUILDING
(more than 90')

MOST MID RISE BUILDINGS
(less than 90')

MOST LOW RISE BUILDINGS
(less than 3 stories)

Panel Options

Panel Options

Panel Options



SEE PAGE 10 FOR OPTIMIZED SIZING FOR FABRICATION.

DISCLAIMER: Wind loads on a building vary by geographic location of the building and zone of the building to which rainscreens will be applied. Buildings closer to the ocean or an embankment have higher wind loads. Corners of buildings also have higher wind loads. Please consult your EOR to determine your wind loading. BÖK can also provide preliminary wind loading analysis. Historical analysis shows that Low Rise buildings tend to have wind loads in the 17-25 PSF range, Mid Rise building have wind loads in the 30-60 PSF range, and high rise buildings have wind loads in excess of 60 PSF.

NOTES: These table are for our pre-engineered panels and are based on our standard 2" deep panel. Panel sizes can be modified by varying depth, fastener type, etc. All projects must be reviewed for final engineering.

TAB & SLOT RAINSCREEN

- Introduction
- Thermal Expansion and Critical Lighting
- 2D Patterns
- 3D Patterns
- **Pre Engineered Sizing**
- Optimized Sizing For Cost Efficiency
- Installation Examples
- Installation Methods
- Typical Details

PRE ENGINEERED SIZING [0.080" ALUMINUM & 14 GA CORTEN]

BOK MODERN ALUMINUM PRE-ENGINEERED RAINSCREEN PANEL DESIGN TABLES *Based on maximum wind loading (psf)*
DEFLECTION CRITERIA *All loading based on L/60*

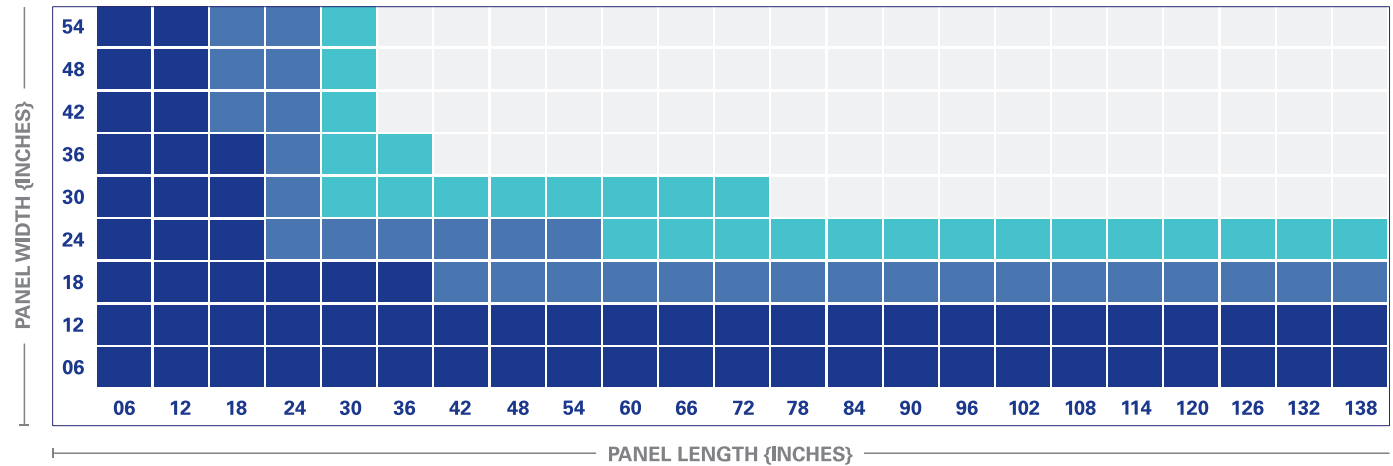

HIGH RISE BUILDING
(more than 90')

MOST MID RISE BUILDINGS
(less than 90')

MOST LOW RISE BUILDINGS
(less than 3 stories)

Panel Options

Panel Options

Panel Options



SEE PAGE 10 FOR OPTIMIZED SIZING FOR FABRICATION.

DISCLAIMER: Wind loads on a building vary by geographic location of the building and zone of the building to which rainscreens will be applied. Buildings closer to the ocean or an embankment have higher wind loads. Corners of buildings also have higher wind loads. Please consult your EOR to determine your wind loading. BOK can also provide preliminary wind loading analysis. Historical analysis shows that Low Rise buildings tend to have wind loads in the 17-25 PSF range, Mid Rise building have wind loads in the 30-60 PSF range, and high rise buildings have wind loads in excess of 60 PSF.

NOTES: These table are for our pre-engineered panels and are based on our standard 2" deep panel. Panel sizes can be modified by varying depth, fastener type, etc. All projects must be reviewed for final engineering.

TAB & SLOT RAINSCREEN

- Introduction
- Thermal Expansion and Critical Lighting
- 2D Patterns
- 3D Patterns
- Pre Engineered Sizing
- Optimized Sizing For Cost Efficiency
- Installation Examples
- Installation Methods
- Typical Details

BOK MODERN ALUMINUM PRE-ENGINEERED RAINSCREEN PANEL DESIGN TABLES *Based on maximum wind loading (psf)*
DEFLECTION CRITERIA *All loading based on L/60*

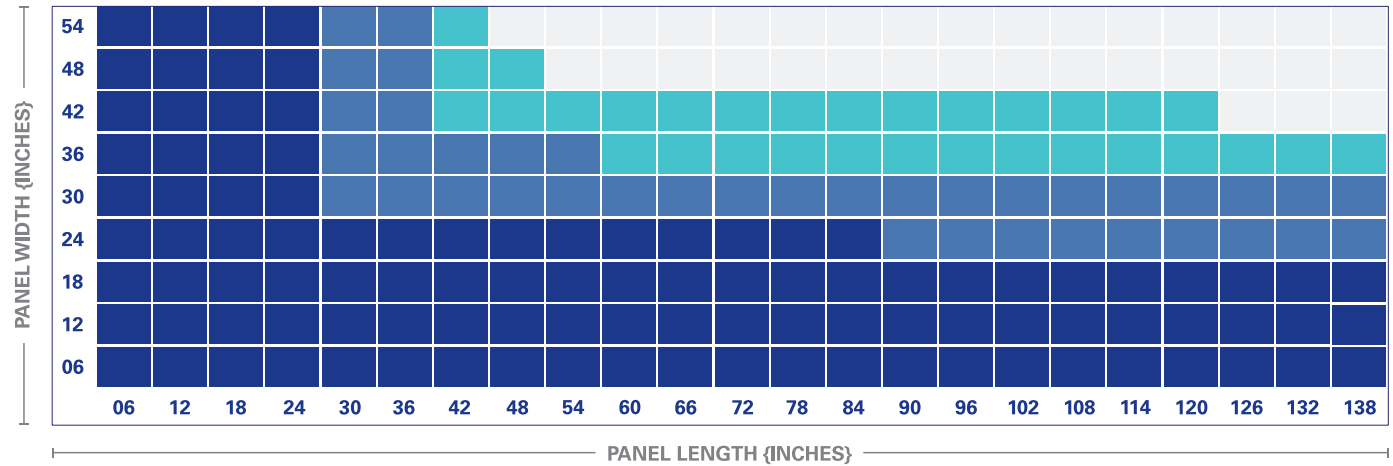

HIGH RISE BUILDING
(more than 90')

MOST MID RISE BUILDINGS
(less than 90')

MOST LOW RISE BUILDINGS
(less than 3 stories)

Panel Options

Panel Options

Panel Options



SEE PAGE 10 FOR OPTIMIZED SIZING FOR FABRICATION.

DISCLAIMER: Wind loads on a building vary by geographic location of the building and zone of the building to which rainscreens will be applied. Buildings closer to the ocean or an embankment have higher wind loads. Corners of buildings also have higher wind loads. Please consult your EOR to determine your wind loading. BOK can also provide preliminary wind loading analysis. Historical analysis shows that Low Rise buildings tend to have wind loads in the 17-25 PSF range, Mid Rise building have wind loads in the 30-60 PSF range, and high rise buildings have wind loads in excess of 60 PSF.

NOTES: These table are for our pre-engineered panels and are based on our standard 2" deep panel. Panel sizes can be modified by varying depth, fastener type, etc. All projects must be reviewed for final engineering.

TAB & SLOT RAINSCREEN

- Introduction
- Thermal Expansion and Critical Lighting
- 2D Patterns
- 3D Patterns
- Pre Engineered Sizing
- **Optimized Sizing For Cost Efficiency**
- Installation Examples
- Installation Methods
- Typical Details

The panels sizes below are optimized sizing for fabrication for cost efficiency. Some of the panels sizes are based on L/60 loading, deflection criteria (see pg. 7, 8 and 9). Some panel sizes, depending on size and gauge will need built in stiffeners to meet your engineering requirements. Please inquire about obtaining engineering assistance of your configuration of panel sizes.

GROUP 1	GROUP 2	GROUP 3
18 x 48	12 x 48	12 x 96
24 x 48	12 x 60	12 x 120
24 x 60	18 x 96	
36 x 48	24 x 96	
42 x 48	24 x 120	
48 x 48		
48 x 60		

MATERIALS

Aluminum [.80 + .125]
Corten [12 or 14 GA]

FINISHES

Kynar Finish
Powder Finish
Anodized

MOST COST EFFECTIVE WAY TO SPECIFY OUR RAINSCREENS: 80/20 RULE

- 80%: Up to 3 typical panels sizes from the same group
 - 20%: Any panels size within 5' X 10' material
- Solid, 2" bends and 1,000 SF minimum.

Our pricing ranges from \$15.60 PSF to \$24.70 PSF for typical panels and additional \$5.00 - \$20.00 PSF for custom panels, for design and shop drawings, depending on locations of custom panels.

All projects must be reviewed for final engineering.

INSTALLATION EXAMPLES

**TAB & SLOT
RAINSCREEN**

- Introduction
- Thermal Expansion and Critical Lighting
- 2D Patterns
- 3D Patterns
- Pre Engineered Sizing
- Optimized Sizing For Cost Efficiency
- **Installation Examples**
- Installation Methods
- Typical Details



DIRECT MOUNT OVER WOOD FRAMING & SHEATHING



HAT CHANNEL OVER EXTERIOR INSTALLATION

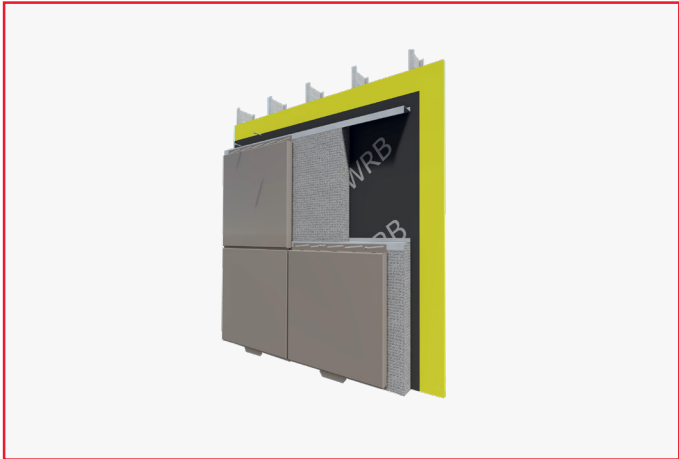

Z CHANNEL OVER EXTERIOR BATT INSTALLATION



EXAMPLES PATTERN AND COLOR VARIATION

TAB & SLOT RAINSCREEN

- Introduction
- Thermal Expansion and Critical Lighting
- 2D Patterns
- 3D Patterns
- Pre Engineered Sizing
- Optimized Sizing For Cost Efficiency
- Installation Examples
- Installation Methods**
- Typical Details

INSTALLATION METHODS

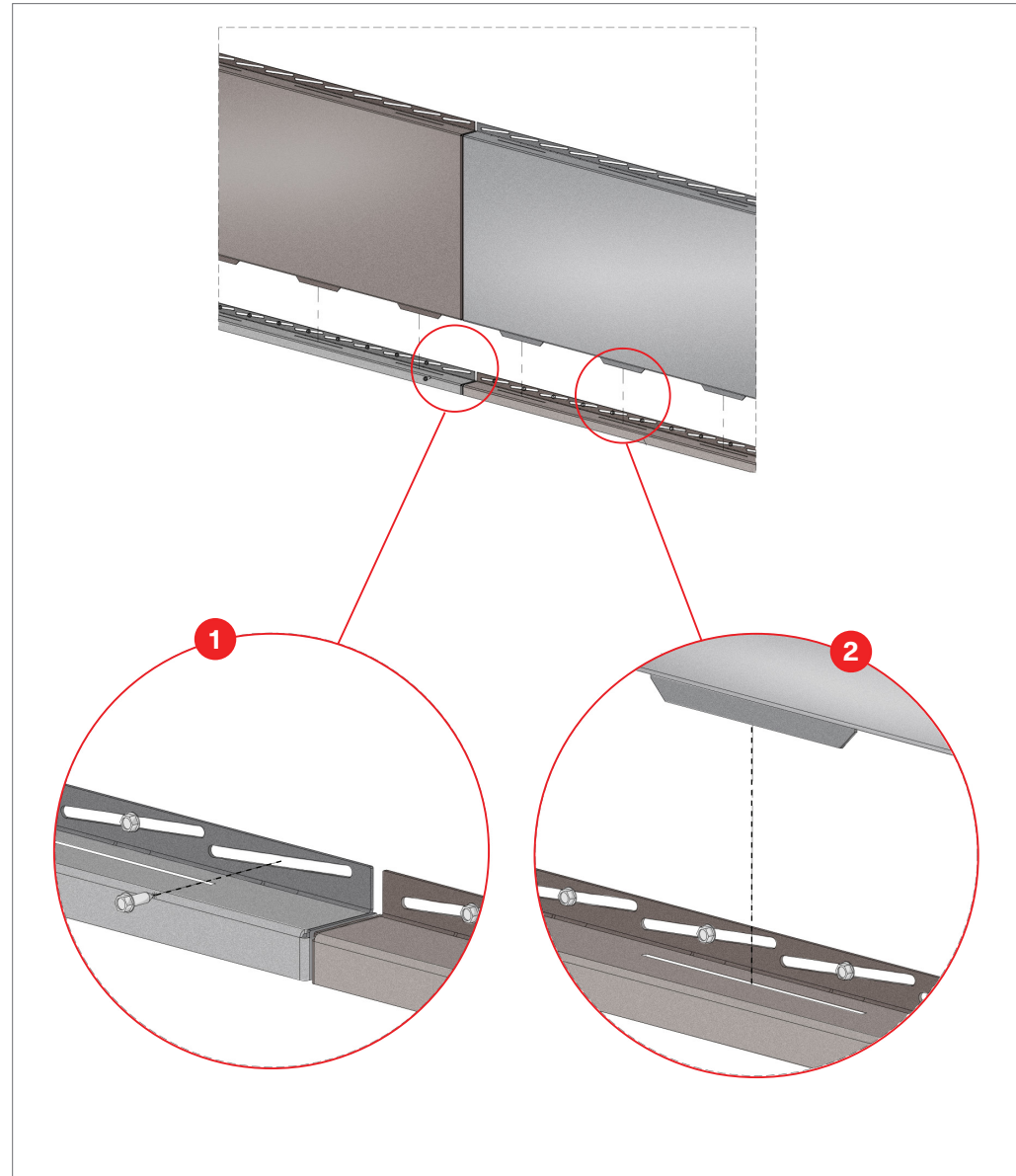

STEP 1

Attach starter strip to structure and level.

STEP 2

Place tabs with integral spacers into slots

TAB & SLOT RAINSCREEN

- Introduction
- Thermal Expansion and Critical Lighting
- 2D Patterns
- 3D Patterns
- Pre Engineered Sizing
- Optimized Sizing For Cost Efficiency
- Installation Examples
- **Installation Methods**
- Typical Details

INSTALLATION METHODS

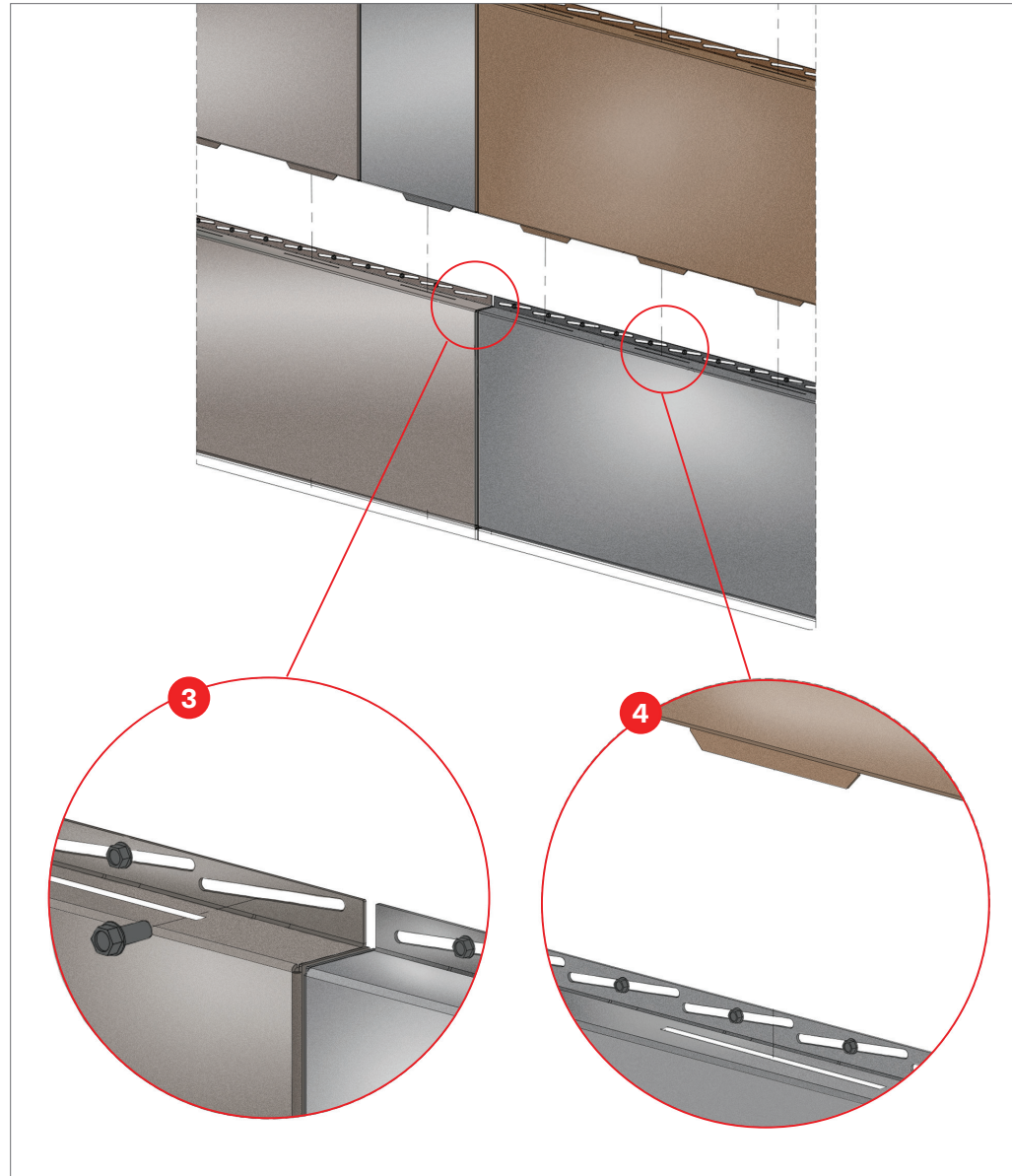

STEP 3

Attach panel to structure and check levelness.

STEP 4

Repeat step 2

**TAB & SLOT
RAINSCREEN**

- Introduction
- Thermal Expansion and Critical Lighting
- 2D Patterns
- 3D Patterns
- Pre Engineered Sizing
- Optimized Sizing For Cost Efficiency
- Installation Examples
- **Installation Methods**
- Typical Details

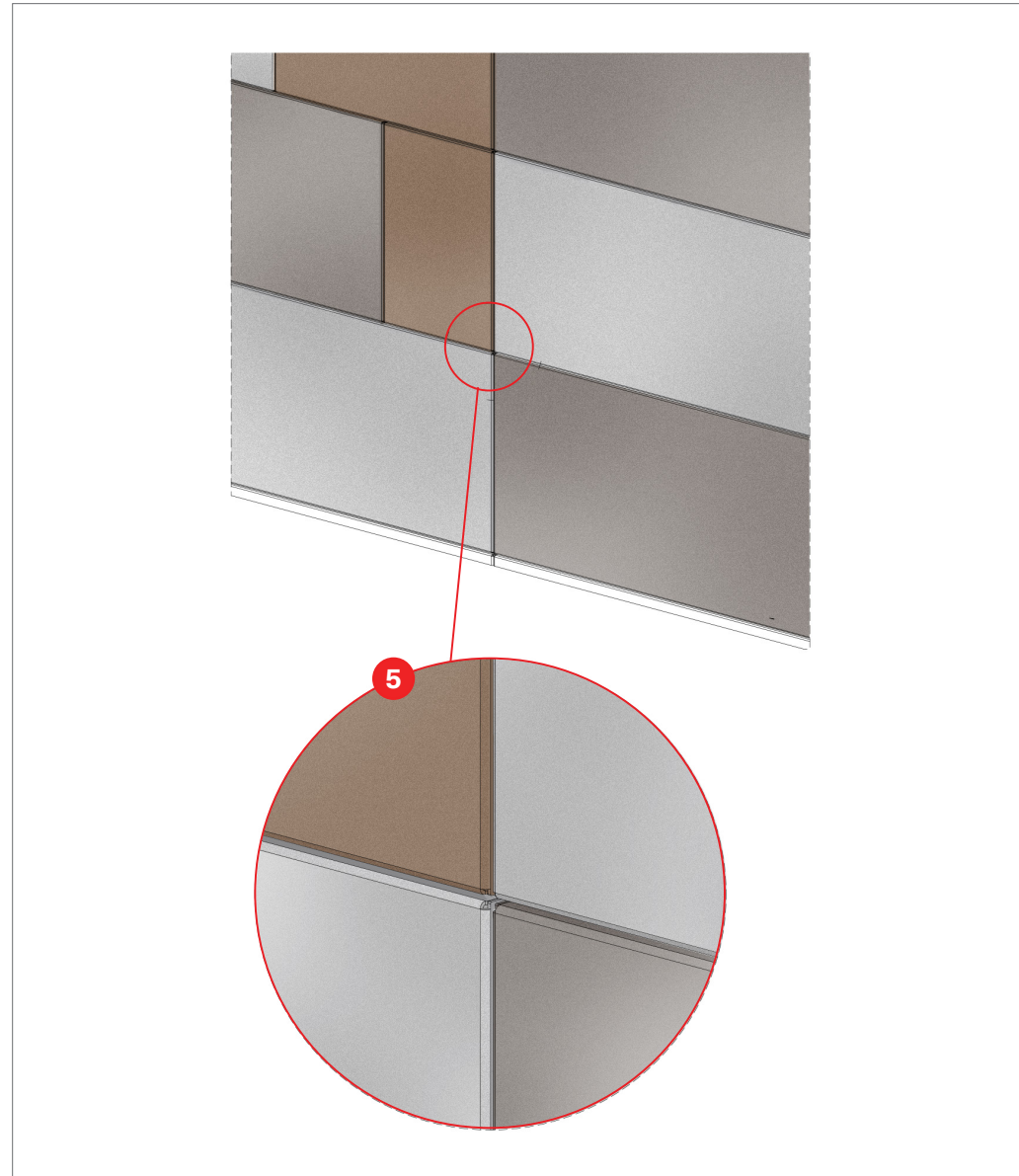

STEP 5

Continue with next row checking alignments.

**TAB & SLOT
RAINSCREEN**

- Introduction
- Thermal Expansion and Critical Lighting
- 2D Patterns
- 3D Patterns
- Pre Engineered Sizing
- Optimized Sizing For Cost Efficiency
- Installation Examples
- Installation Methods
- Typical Details

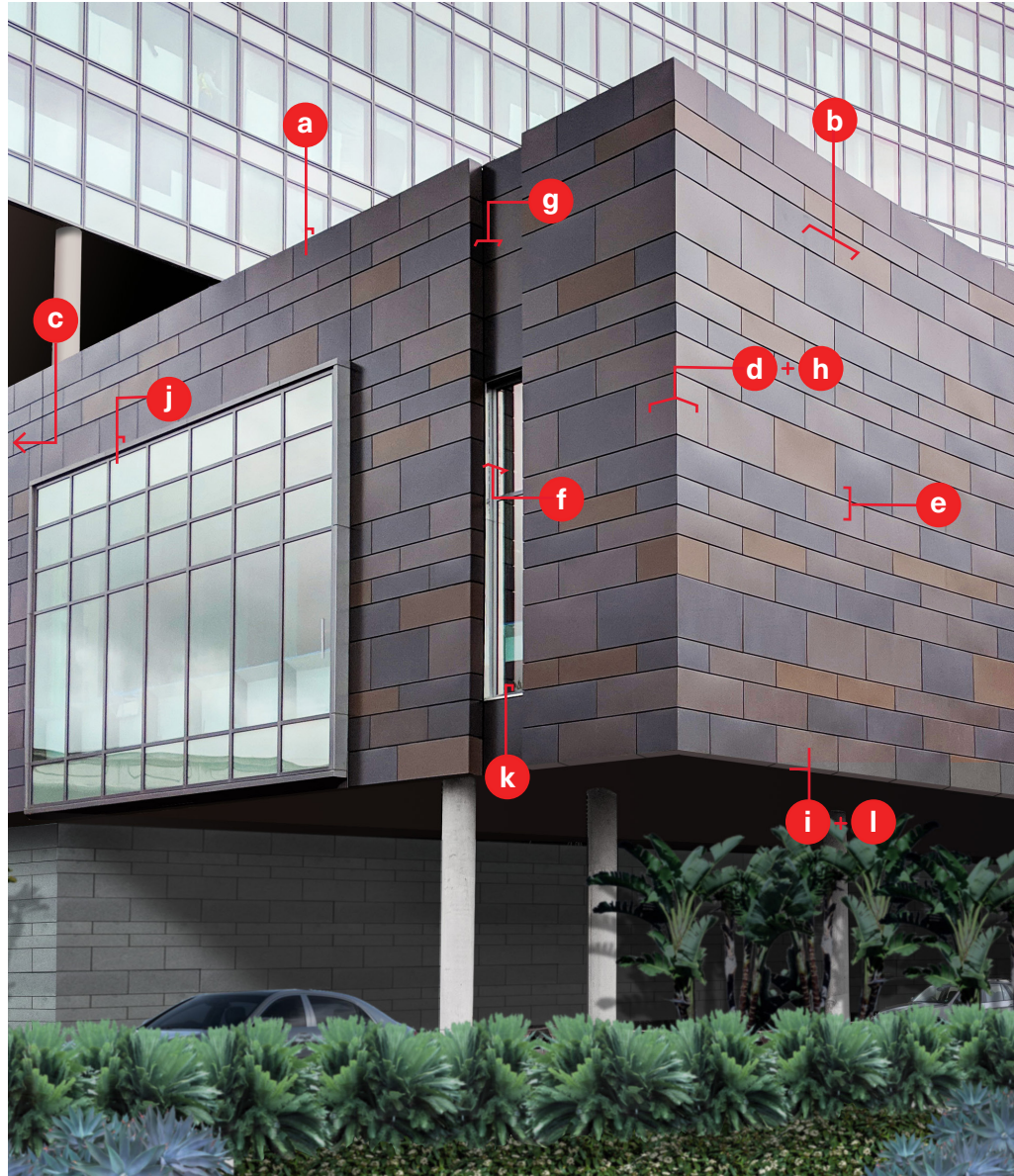

DETAIL KEY

- Ⓐ Panel at cap flashing
- Ⓑ Vertical joint
- Ⓒ End condition
- Ⓓ Mitered corner
- Ⓔ Horizontal joint
- Ⓕ Panel at jamb
- Ⓖ Inside corner
- Ⓗ Folded corner
- Ⓘ Panel at starter strip
- ⓵ Panel at head
- Ⓚ Panel at sill
- Ⓛ Soffit condition

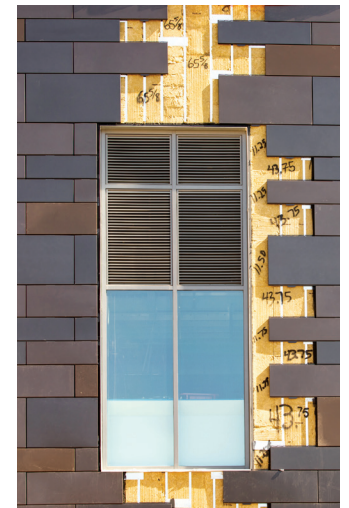

**TAB & SLOT
RAINSCREEN**

- Introduction
- Thermal Expansion and Critical Lighting
- 2D Patterns
- 3D Patterns
- Pre Engineered Sizing
- Optimized Sizing For Cost Efficiency
- Installation Examples
- Installation Methods
- **Typical Details**

TYPICAL DETAILS

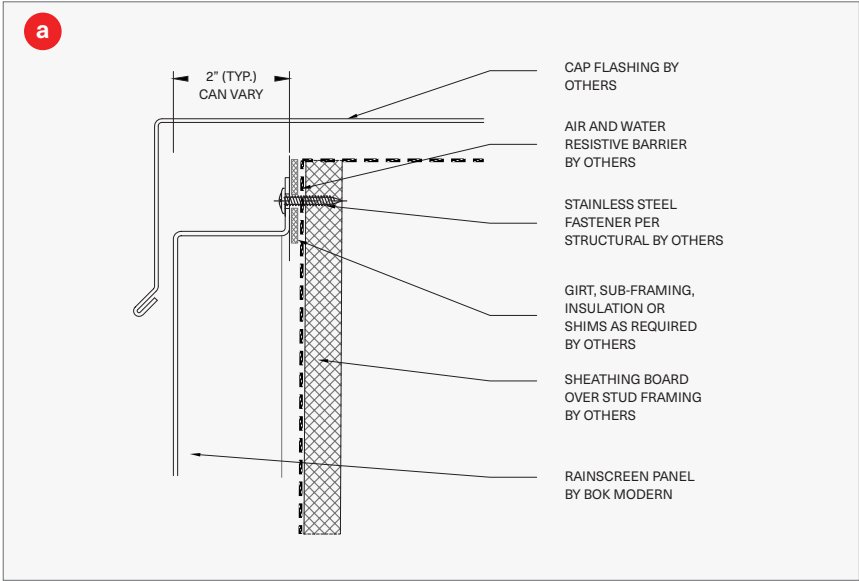

**PANEL AT CAP
FLASHING**

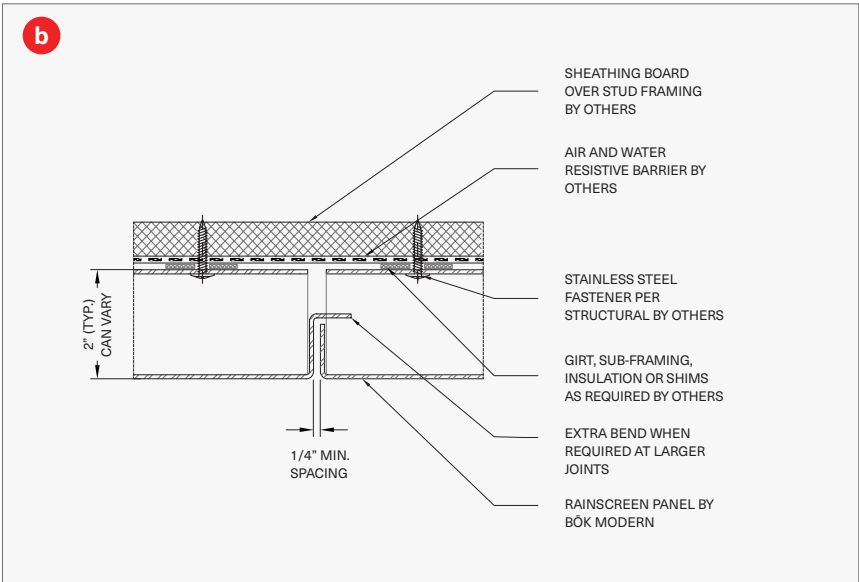

VERTICAL JOINT

**TAB & SLOT
RAINSCREEN**

- Introduction
- Thermal Expansion and Critical Lighting
- 2D Patterns
- 3D Patterns
- Pre Engineered Sizing
- Optimized Sizing For Cost Efficiency
- Installation Examples
- Installation Methods
- **Typical Details**

TYPICAL DETAILS

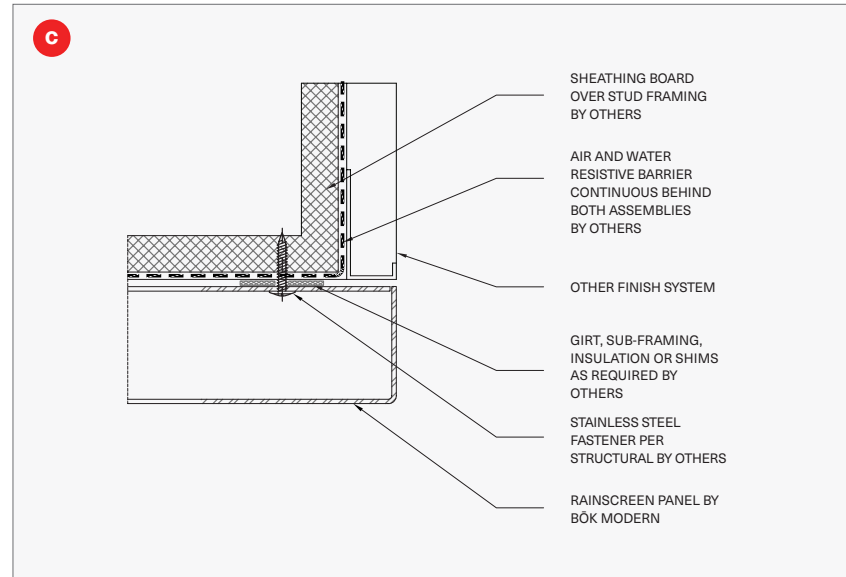

END CONDITION

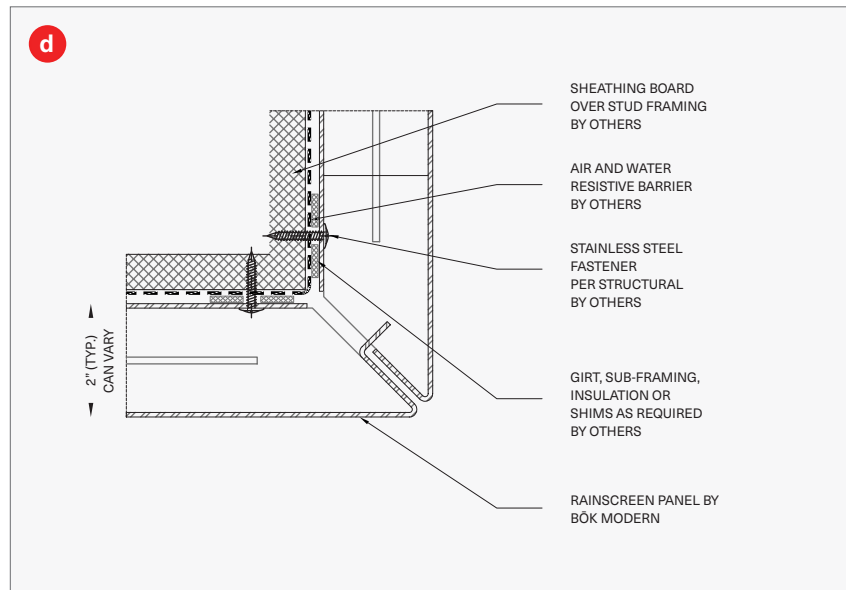

MITERED CORNER

**TAB & SLOT
RAINSCREEN**

- Introduction
- Thermal Expansion and Critical Lighting
- 2D Patterns
- 3D Patterns
- Pre Engineered Sizing
- Optimized Sizing For Cost Efficiency
- Installation Examples
- Installation Methods
- **Typical Details**

TYPICAL DETAILS

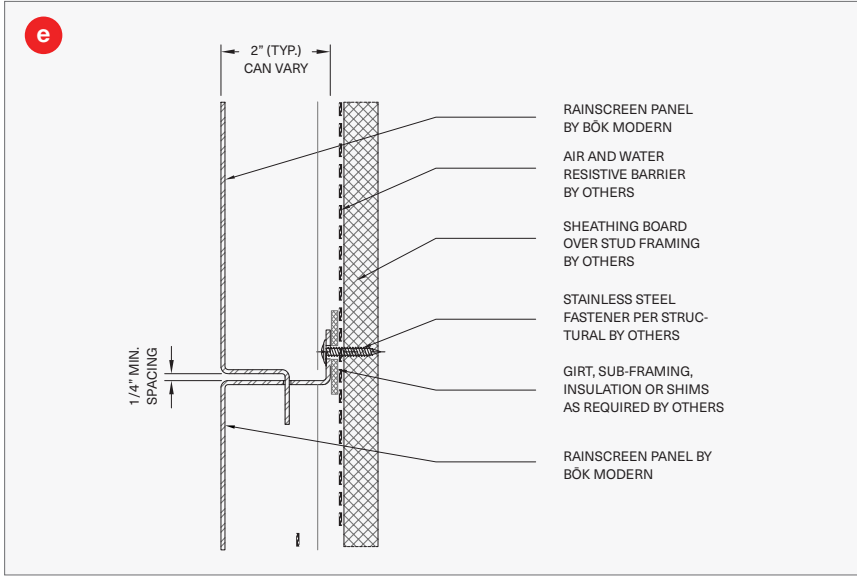

HORIZONTAL JOINT

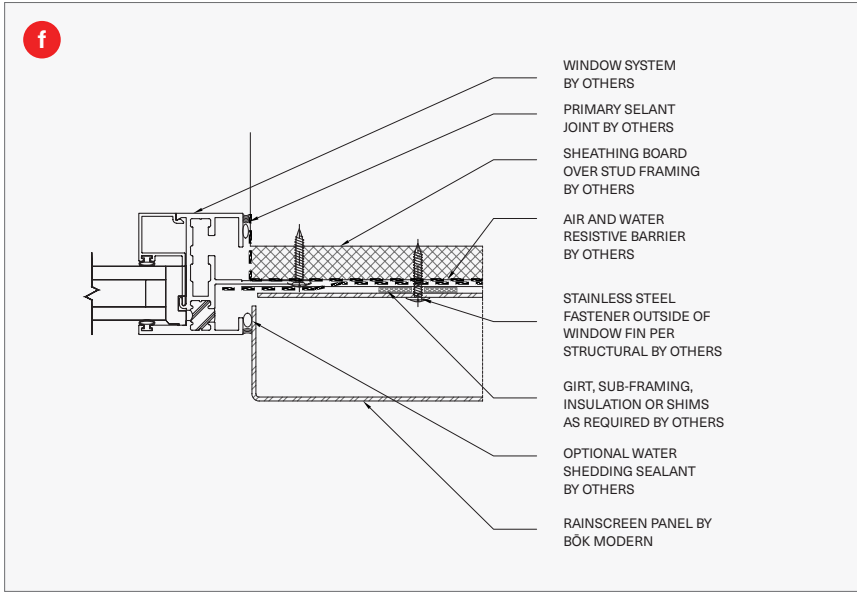

PANEL AT JAMB

**TAB & SLOT
RAINSCREEN**

- Introduction
- Thermal Expansion and Critical Lighting
- 2D Patterns
- 3D Patterns
- Pre Engineered Sizing
- Optimized Sizing For Cost Efficiency
- Installation Examples
- Installation Methods
- **Typical Details**

TYPICAL DETAILS

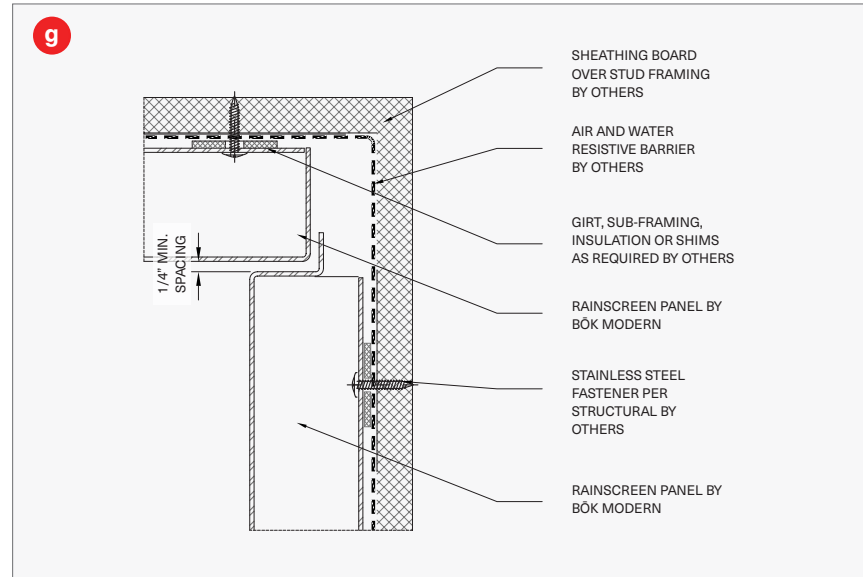

INSIDE CORNER

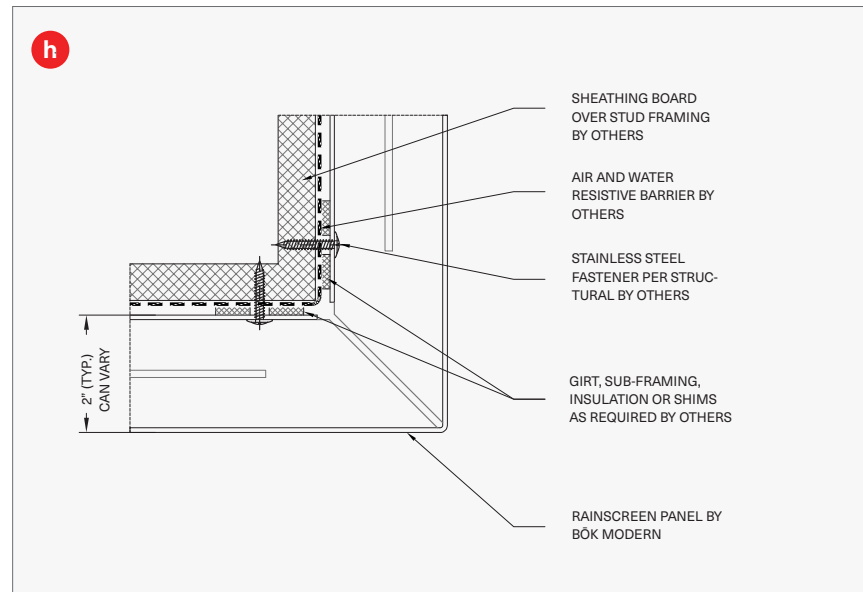

FOLDED CORNER

**TAB & SLOT
RAINSCREEN**

- Introduction
- Thermal Expansion and Critical Lighting
- 2D Patterns
- 3D Patterns
- Pre Engineered Sizing
- Optimized Sizing For Cost Efficiency
- Installation Examples
- Installation Methods
- **Typical Details**

TYPICAL DETAILS

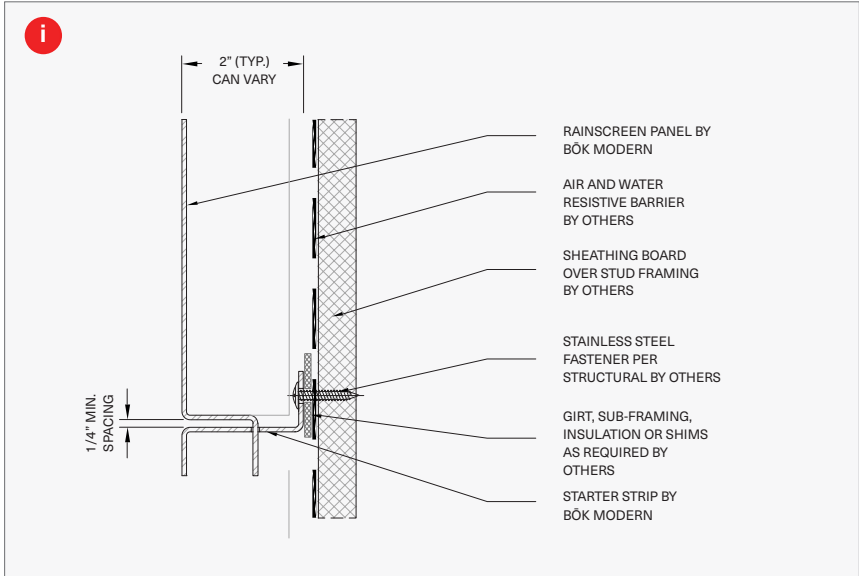

**PANEL AT
STARTER STRIP**

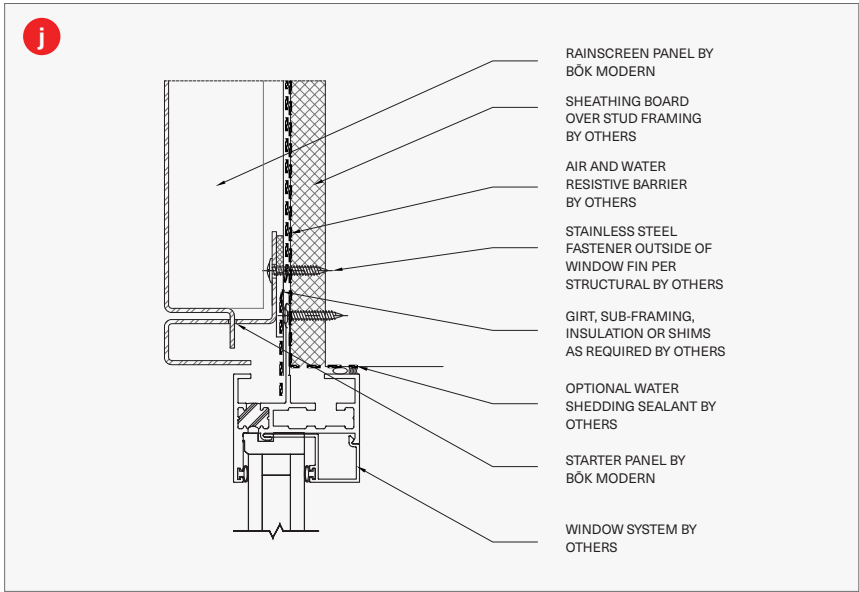

PANEL AT HEAD

**TAB & SLOT
RAINSCREEN**

- Introduction
- Thermal Expansion and Critical Lighting
- 2D Patterns
- 3D Patterns
- Pre Engineered Sizing
- Optimized Sizing For Cost Efficiency
- Installation Examples
- Installation Methods
- **Typical Details**

TYPICAL DETAILS

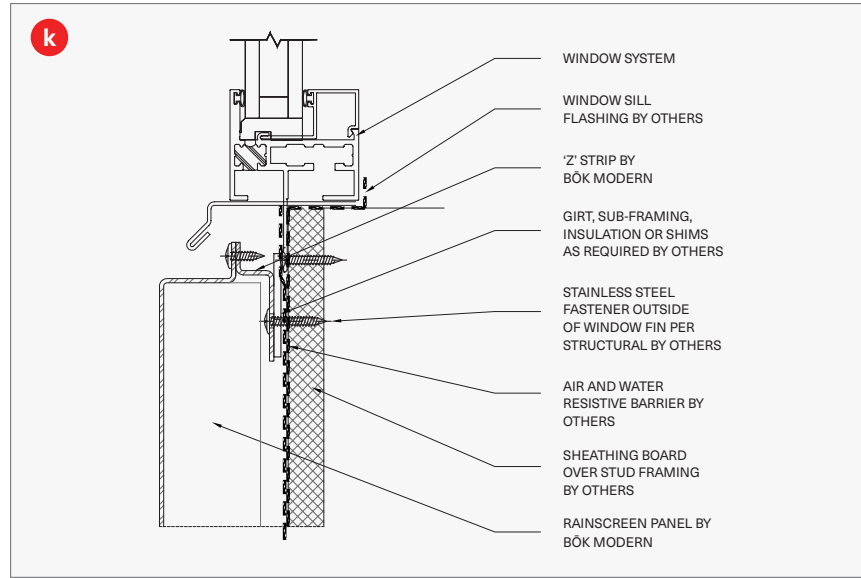

PANEL AT SILL

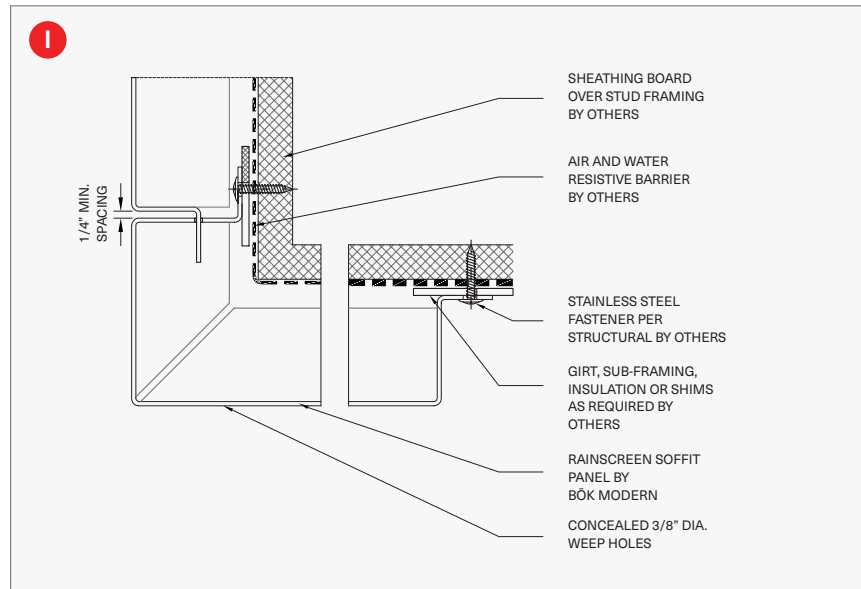

SOFFIT CONDITION